



**Know Your Loads, Weights and Forces for a Safe  
and Secure Operation**

# Facts & Figures

## About BROSA

### Headquarters

**BROSA GmbH**, Tett nang, Germany

- Production and R&D Sensors

### Subsidiaries

**Rüthi Electronic AG**, Switzerland

- Production and R&D Electronics, SW

**BROSA B.V.**, Oss, Netherlands

- Sales Office

**BROSA Pte Ltd**, Singapore

- Sales Office

**BROSA (Nanjing) Co., Ltd.**, China

- Sales Office

### Key Figures

- Founded in 1935
- 100 Employees
- ISO 9001 and ISO 14001 certified



# Facts & Figures

## About BROSA

- Products are developed in close collaboration with our customers
- Understanding the Trends & Industries
- Compliance with worldwide safety standards
- “Made in Germany” The logo for "Made in Germany", featuring a stylized German flag (black, red, and gold horizontal stripes) to the left of the text "Made in Germany" in a bold, black sans-serif font.
- More than 90% in house manufacturing
- Full scope of product engineering and manufacturing
  - Specification
  - Technical proposals
  - Production: mechanical, electrical, assembly
  - Calibration
  - Certification, Type Approvals,
  - Customer Acceptance Tests



# Product Portfolio



Force measuring pin



Tension load cell



Force sensor washer



Tubular load cell



Compression load cell



Weighing and Overload Systems



Support jack load cell



Angle sensor MEMS



Normal force sensor



Sensor for Ex area



Pressure transducer



Pressure transducers



BROSA electronics

# Safety Sensor Concept

Acc. DIN EN ISO13849 & IEC 61508

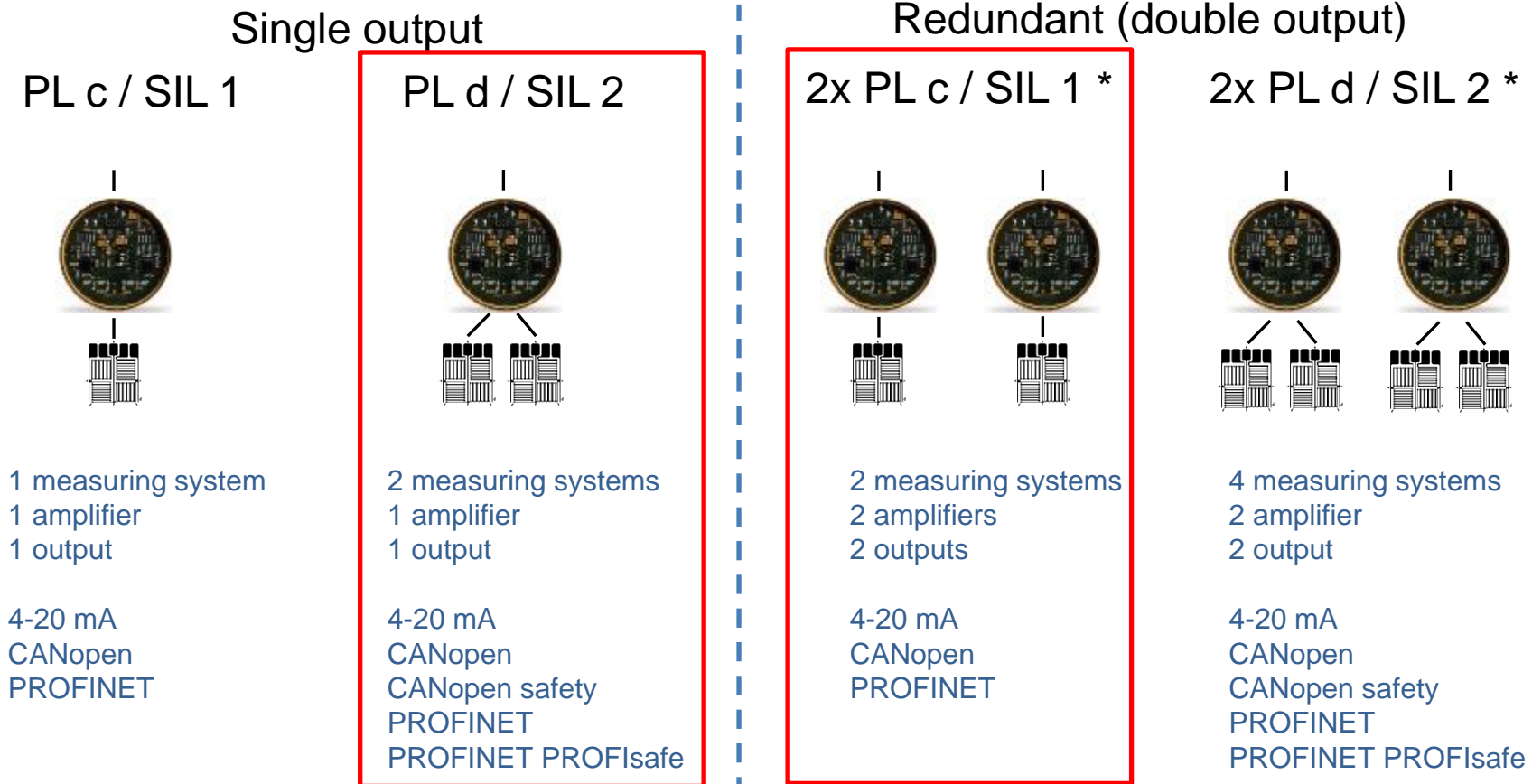

\* PL e / SIL 3 is possible if used in parent systems DIN EN ISO 13849-1



# Safety System Concept

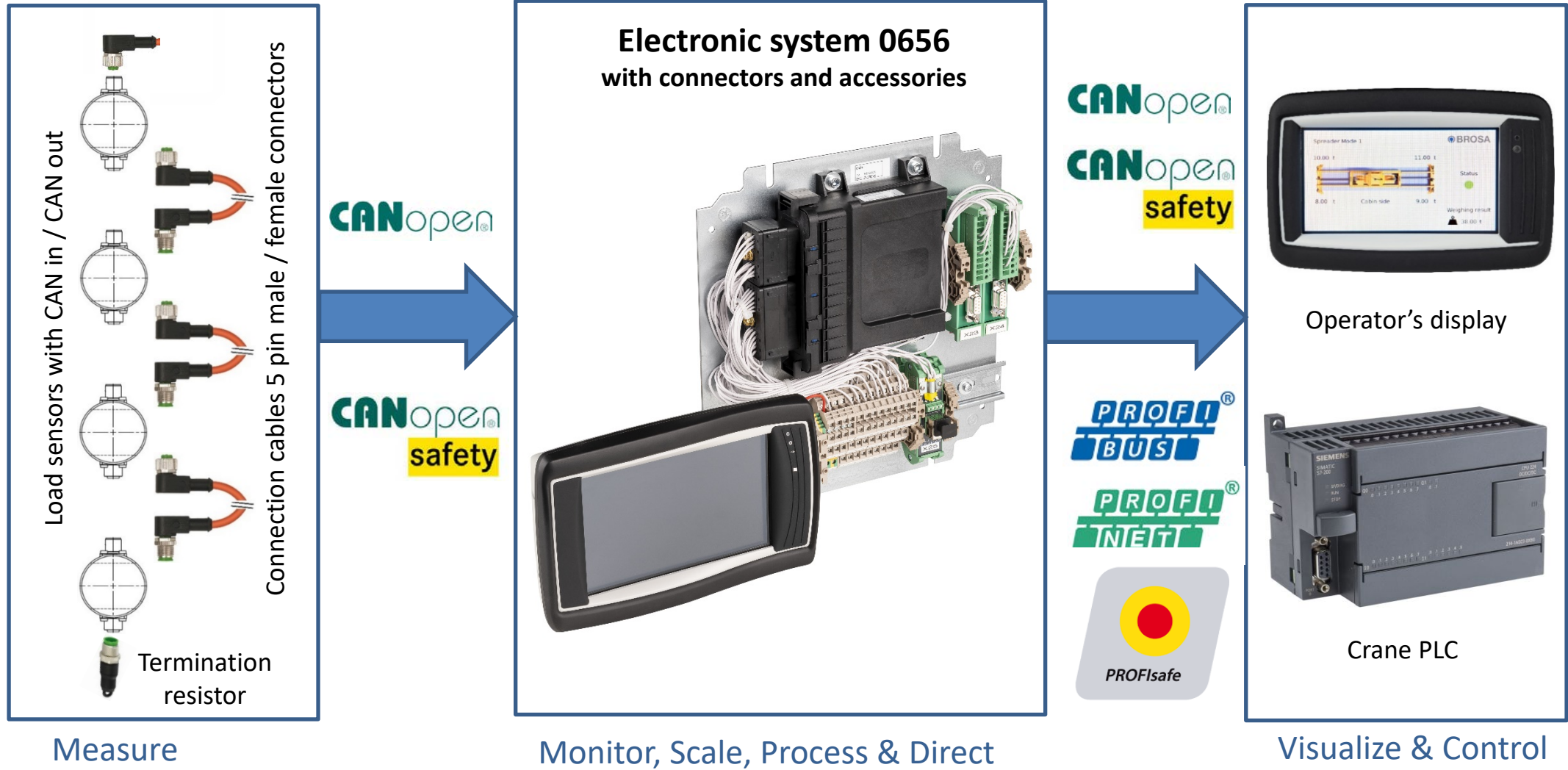

# Certificates

## Weighing & Safety, FMEA, OIML Certificate

### Key Data from RP & FMEA

- Standard: IEC 61508 / DIN EN ISO 13849
- Architecture-Category
- Probability of a dangerous failure (PFH)
- Mean Time to a dangerous Failure (MTTF<sub>d</sub>)
- Diagnostic Coverage of dangerous failures (DC)
- Mission time
- Resulting in Safety Integrity Level
  - SIL2 = PL<sub>d</sub>

Project No. LUD013D024	DANGmicro (2 Messbrücken)
Issue: 01	Reliability Prediction

1 Overview:

Block-Nr.	
Block-Na.	
Architecture	
DO	
DU	
SD	
SU	
DC	
τ <sub>0</sub>	
τ <sub>0</sub> / τ <sub>1</sub>	
PFH	
Requirement	
PFH <sub>d</sub>	
SIL <sub>PL</sub>	
SIL	
Requirement	
MTTF	
DC	
PL	

Project Nr. LUD013D024	DANGmicro (2 Messbrücken)
Issue: 02	Reliability Prediction

### OVERVIEW

The following failure rates have been determined:  
[Für das Projekt DANGmicro (2 Messbrücken ermittelt):]

$$\begin{aligned} \lambda_{SD} &= 0,0502 \cdot 10^{-6} \text{ H}^{-1} \\ \lambda_{SU} &= 0,1230 \cdot 10^{-6} \text{ H}^{-1} \\ \lambda_{DU} &= 0,1797 \cdot 10^{-6} \text{ H}^{-1} \\ \lambda_{DU} &= 0,0087 \cdot 10^{-6} \text{ H}^{-1} \end{aligned}$$

The MTTF<sub>d</sub> value of all dangerous failures is  
[Die MTTF<sub>d</sub> aller gefährlichen Ausfälle beträgt]

$$\text{MTTF}_d = 606 \text{ (100*) years (Jahre)}$$

\* According to the DIN EN ISO 13849-1 years.  
[Der MTTF<sub>d</sub> ist nach DIN EN ISO 13849-1 au

The resulting diagnostic coverage of dangerous failures is  
[Es ergibt sich ein Diagnoseabdeckungsgrad]

$$\text{DC} = 95,40 \%$$

These values correspond to performance according to the table K1 in the DIN EN ISO 13849-1  
[Nach Tabelle K1 der DIN EN ISO 13849-1 einem Performance Level d.]

The probability of a dangerous failure (PFH) is  
[Die Wahrscheinlichkeit eines gefährlichen Ausfalls beträgt:]

$$\text{PFH} = 4,04 \cdot 10^{-9} \text{ H}^{-1}$$

The Safety Integrity Level, relative to the determined PFH is  
[Der Sicherheits-Integritätslevel (SIL), bezogen auf die Wahrscheinlichkeit eines gefährlichen Ausfalls beträgt:]

$$\text{PL}_d = \text{SIL-2}$$

Standards and Handbooks (Normen & Zuverlässigkeitsstandards):

IEC TR62380	DIN EN ISO 13849-1
FMD-91	DIN EN ISO 13849-2
IEC 62061	IEC 61508

Tobias Luderer - Elektronik Analyse

LUD013D0402



### OIML BASIC CERTIFICATE OF CONFORMITY

OIML Member State  
SWEDEN



### OIML BASIC CERTIFICATE OF CONFORMITY

OIML Certificate No.  
R60/2000-SE1-17.01



#### Identifi

#### General

The load

integrat

The ring

such as

position

Technic

Max cap

Min cap

Interval

Minimum

verificat

EMC cla

Temper

Power s

Apportic

Interfa

The load

CANopi

#### Applicant

Name:

Brosa AG

Address:

Dr.-Klein-Straße 1, D-88069 Tettnang, Germany

#### Issuing authority

Name:

SP Technical Research Institute of Sweden

Address:

Box 857, SE-501 15 Borås, Sweden

Person responsible:

Lennart Aronsson

Manufacturer of the certified pattern is the applicant.

#### Identification of the certified pattern

A graduated, self-indicating, electronic, automatic weighing instrument.

Identification of

Digital load cell

the certified type

Type: 0120

Accuracy class

D(0,23)

Number of verification scale intervals

n ≤ 230

(Identification continued on next page.)

This certificate attests the conformity of the above-mentioned pattern (represented by the samples identified in the associated test report) with the requirements of the following Recommendation(s) of the International Organization of Legal Metrology (OIML):

R60, edition 2000.

This certificate relates only to the metrological and technical characteristics of the pattern of the instrument concerned, as covered by the relevant OIML International Recommendation(s).

This certificate does not bestow any form of legal international approval.

The conformity was established by tests described in the associated test report 6P07480-01-1 dated 2017-01-20. This is the first issue of this certificate.

Borås, January 23, 2017

SP Technical Research Institute of Sweden

Certification

Lennart Aronsson

Bengt Gutfelt



OIML Certificate No.

SP Technical Re

Box 857, SE-501 15 B

Phone: +46 10-516 50

E-mail/internet: info@sp.se

OIML Certificate of Conformity no R60/2000-SE1-17.01 dated January 23, 2017, page 1 (2)

SP Technical Research Institute of Sweden

Box 857, SE-501 15 Borås, Sweden

Phone: +46 10-516 50 00

E-mail/internet: info@sp.se/www.sp.se

SP has been authorised by the Swedish OIML-member to issue and sign OIML-certificates. Important note: Apart from the mention of the certificate's reference number and the name of the OIML Member State in which the certificate was issued, partial quotation of the certificate or of the associated OIML Basic Type Evaluation report is not permitted, though either may be reproduced in full. SP ref: DC0652-16

# BROSA 3P sensor washer

## Integration of the sensor in a twistlock

- No effect on twistlock cross-section
- Direct force measurement by integrating the sensor into the twistlock assembly
- Tension of the twistlock is transformed into a compression force
- Detachable mechanical assembly
  - Can be re-used during twistlock inspection
  - Can be re-used after twistlock exchange
- Designed and tested for > 2 Mio. load cycles





# Safe Lifting of Loads

## Why Safety Systems

- Nearly 25% of accidents in container ports are load dependant. But not in all cases containers are overloaded.
- Safety systems on lifting equipment are a mandatory requirement when loads are lifted
- Monitoring of Safe Working Limits and Operational Limits at all times
- Safety Systems must comply with Safety Standards
  - European and International Safety Standards
    - Performance Level d (DIN 13849)
    - Safety Integrity Level 2, SIL2 (IEC 61508)

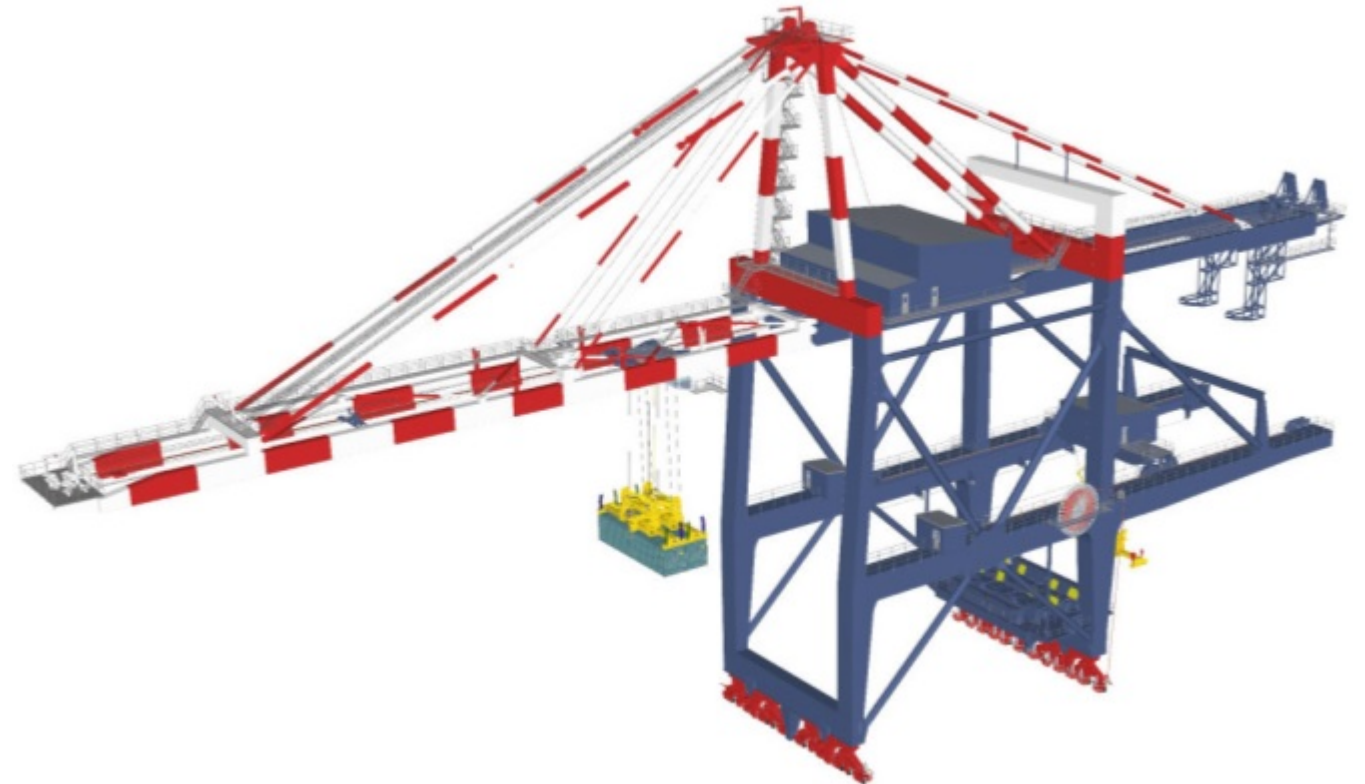

# Additional & Special Functions

## Snag Load Detection

Dangerous situations occurs when

- The container gets stuck in the railings of a vessel during the lift.
- Parts of the spreader block the lift, e.g. flippers
- Head covers are not completely removed and obstruct the lifting area
- ....
- The load sensors are immediately registering a second increase of the load signal
- Once a second increase is detected on any of the load sensors the snag warning can be triggered
- The threshold for the detection is dynamic, dependant on the weight of the container being lifted.

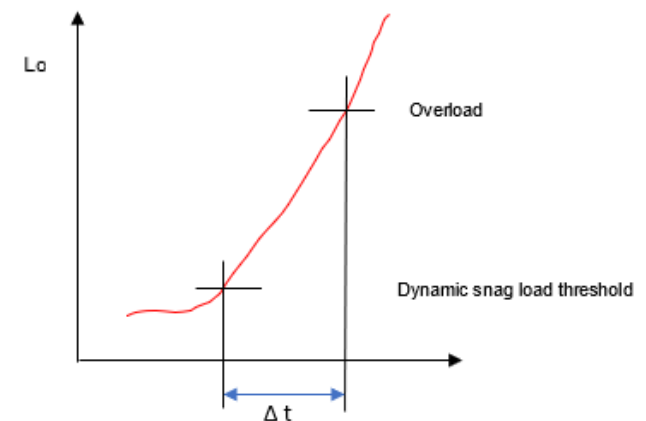
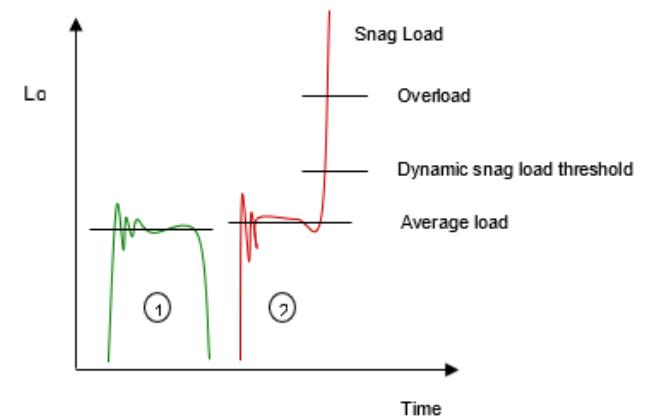

# Additional & Special Functions

## Twin Lift of Containers

Dangerous situations occurs when

- One of the twistlocks is not correctly locked in corner
- For Twin-Spreaders: the twin detection system does not detect 2 containers, so that inner twistlocks will not lock

Enhancement for better detection and much more safe lifts

- Installation of force sensor washer on each twistlock
- Load measurement and plausible load checks by start lifting



# Mobile Port Equipment

## Critical Situations

- Driving at high speed
- Taking turns at high speeds
- Load too high, e.g. at straddle carrier
- Load measurement at the twistlocks reduces the possibility of dangerous situations (known weight and height → better speed control)
- Knowing the centre of gravity and lifting height can also reduce the possibility of dangerous situations (position)





# SOLAS Container Weighing

Started 1<sup>st</sup> of July 2016

- Safety issues for extended functions (e.g. SOLAS)
  - Detection of wrongly declared Container Weights
  - Improvement of Ship Stowage Plans
- General requirements
  - Since 1<sup>st</sup> of July 2016 the VGM of a container must be taken by a verified system before its being loaded onto a vessel
  - Must be possible to weigh two containers
  - Weighing process shall not interfere with container flow
  - Must provide a weighing result that can be used for trading
  - BROSA Weighing system 0656 and force sensor washers are approved to comply with OIML R51, R60 & R76 requirements
  - Country registration to be done by mechanical partner.





# New Developments

## Terminal Automation

- Automation or Industry 4.0 is making his way with big steps into the container handling industry
- Not the individual speed but rather a repeatable speed is the key factor to increase efficiency
- Results shall be sellable time of the operation
- Key Performance Indexes are (next to many others):
  - High equipment availability
  - Minimum downtime (Repairs, Maintenance)
  - Accident prevention
  - Extended equipment lifetime
- Maintenance
  - Corrective maintenance
  - Preventive maintenance
  - Predictive maintenance
- Load sensors and systems to calculate and record lifetime data



# New Developments

## Intelligent Sensors

- For sensor installation in the headblock
- Acceleration = change in velocity
  - Change in speed
  - Change in direction
  - Change in both
- During a lift of a container the hoisting speed accelerates while the trolley movement changes the direction.
- This causes unwanted effects into the measurement of the force created by the container
- The amplifier inside the sensor needs to calculate the dynamic forces
- Result shall be an increase of the overall accuracy of the load measurement by splitting the load signal in a static and a dynamic signal

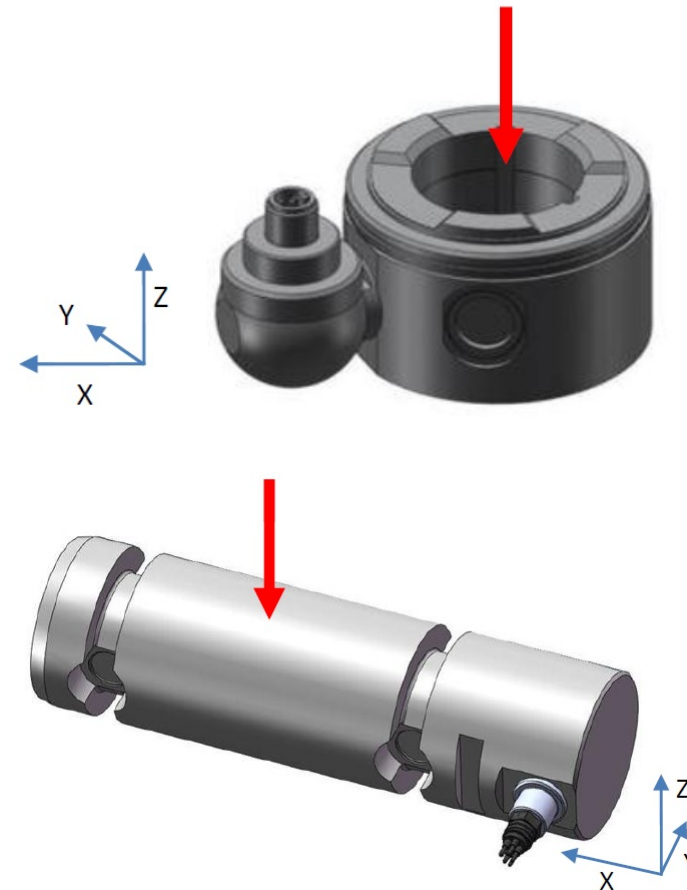

# New Developments

## Lift data vs. Lifetime

### Integrated parameters

#### Sensor

- Service hour meter
- Load collective
- Load cycles
- Overload counter

#### System

- Time based parameters

#### Calculation for

- Maintenance intervals
- Machine fatigue & lifetime
- Etc.....

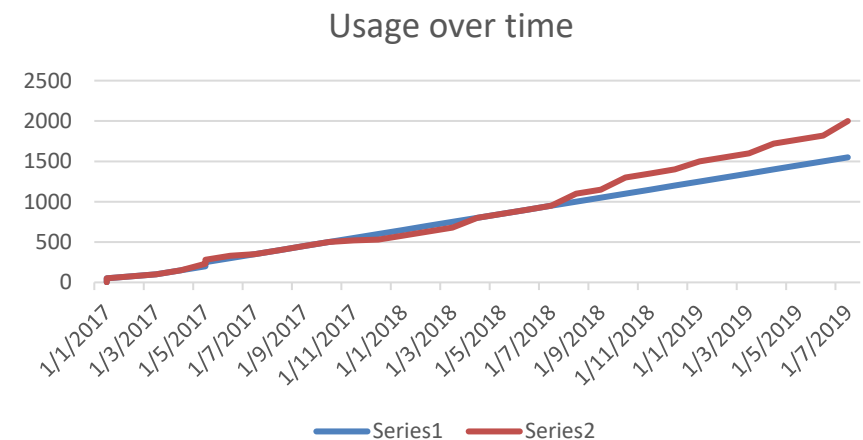
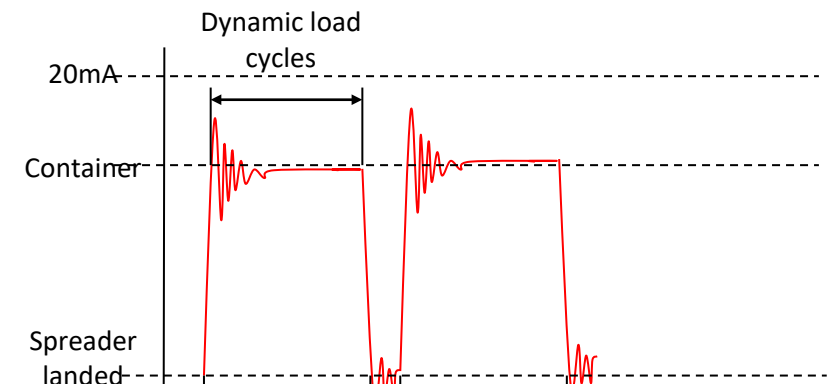

## BROSA GmbH

- A competent partner for load sensing and monitoring
- A leading supplier to the container handling industry
- An innovation driven development partner for future oriented products
- Supplier to all major crane and port equipment manufactures
- Products are used in all major ports around the world.



**END**

**THANK YOU VERY MUCH FOR YOUR ATTENTION**