

# DYNAMIC POSITION DETECTION AND COLLISION AVOIDANCE - RADAR IS THE SOLUTION



**KYMATI**

WAVES ARE OUR VISION

# BUSINESS SEGMENTS – RADAR SOLUTIONS

## INDUSTRIAL AUTOMATION



## CONTAINER TERMINALS



## LARGE DRONES



WAVES ARE OUR VISION

# CONTAINER TERMINAL SOLUTIONS



**KYMATI**

WAVES ARE OUR VISION

# DYNAMIC LOCATION IS KEY

## GNSS/GPS IS NOT SOLVING ALL ISSUES

1. **Container tracking** on yard
2. **Navigation and job assignment** for transport vehicles and cranes
3. **Collision avoidance** in 3D and no-go zones:
4. **Event creation** – exception tracking
5. **Dynamic 3D Visualization – Digital Twin** covering all different makes

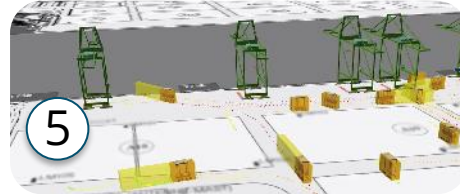
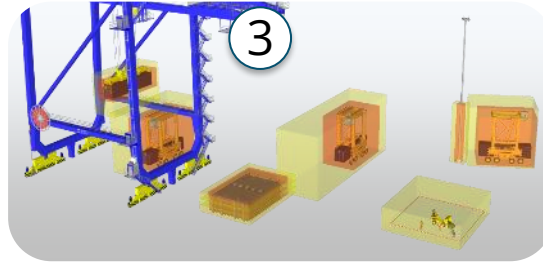
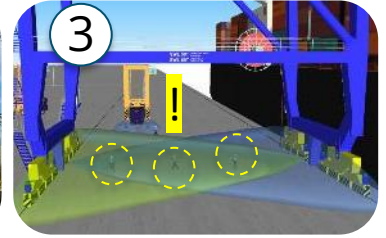

Due to signal reflections, GPS does not work reliable under and close to cranes...  
... and some terminals already consider a complete independence from GPS for geopolitical reasons.



WAVES ARE OUR VISION

# KYMATI @ MPET (ANTWERP, BELGIUM, 50% TIL, 50% PSA) SINGLE LARGEST TERMINAL IN EUROPE

35 STS, 240 STRADS (3HIGH AND 4HIGH) AS OF 2025 ...AND EXPANDING



WAVES ARE OUR VISION

# KY-LOC 2D: PRECISE GPS-DENIED POSITIONING CREATES SAFETY, AWARENESS AND COST REDUCTIONS

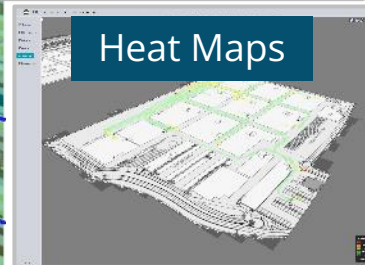
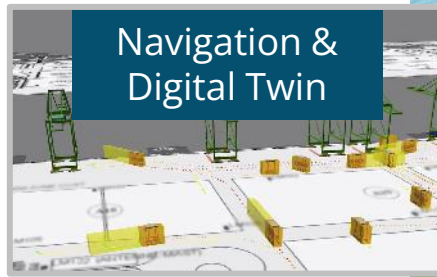
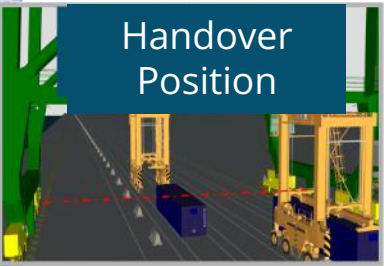
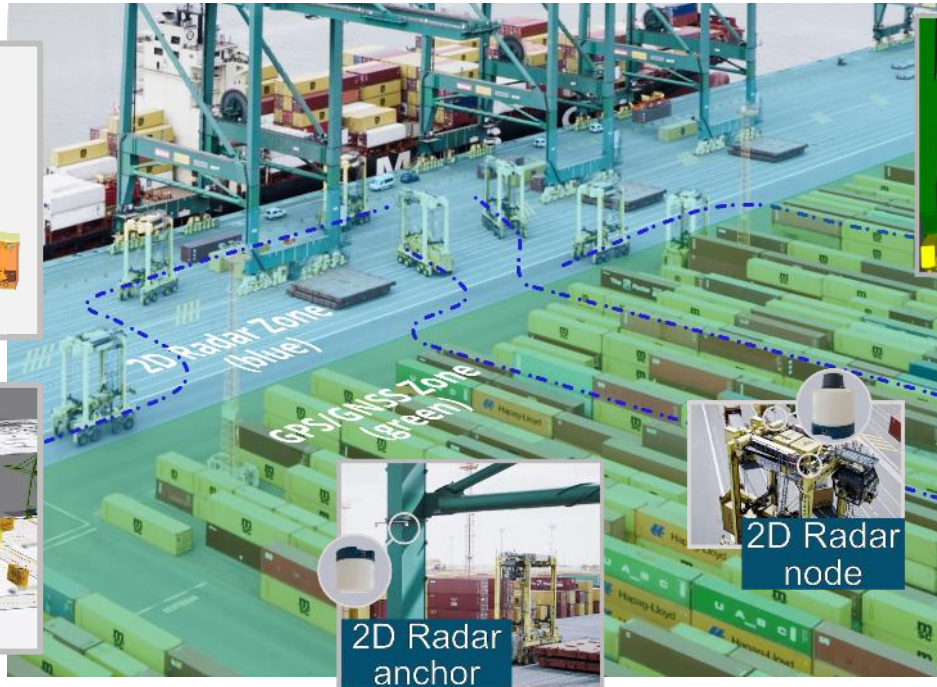
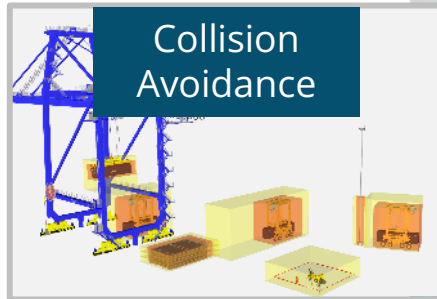

WAVES ARE OUR VISION



# CRANES/VEHICLES CAN WORK LIKE AIRPLANES...

## HOBBY PILOTS COLLISION AVOIDANCE

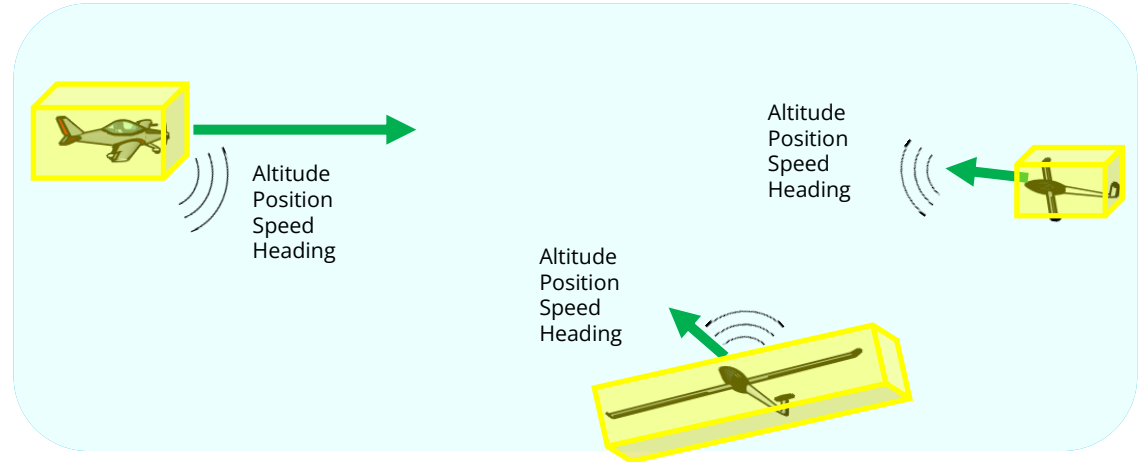

- Small aircraft outside commercial air traffic make use of a send/receive unit with GPS-based position, heading and speed to avoid collisions.
- All units continuously radio broadcast this data, without an established communication partner.
- All units listen in parallel, receive other aircraft's broadcast messages when in receiving distance, and compute their individual collision risk, based on own position, speed and heading, as well as on the movement of those near by.
- Full 3D collision avoidance in any direction
- No central brain/server/operator involved.

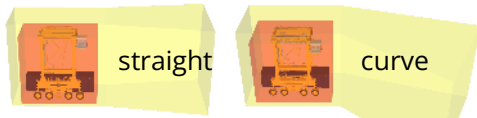

# 3D COLLISION PREVENTION ON TERMINALS

## HIGHLY PRECISE COLLISION ANALYSIS – WARNINGS ONLY IF REQUIRED



-  Individual fixed collision shape
-  Individual, speed and heading dynamic warning shape

Overlap of dynamic warning shapes (yellow) and active movement prediction based on approach speeds:  
=> **warning will be triggered**

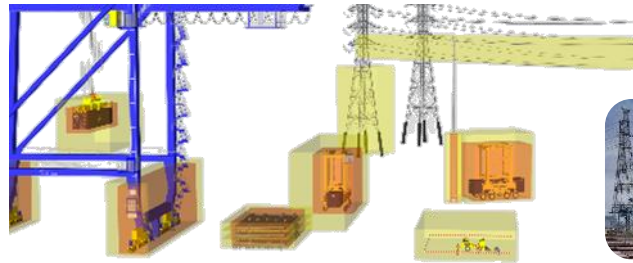

Positions of temporary alert zones (hatch covers, temp. work zones, silent monitoring zones) and permanent obstacles (buildings, light poles, power lines) are stored in the KY-LOC 2D database. Whenever there is an update, the database is redistributed to all CHE.



## BENEFITS

- All CHE have precise position/heading and a collision radio to listen to near-by objects
- Each CHE calculates independent collision risk against other dynamically moving units (vehicles, cranes, containers) and static objects in their local database (updated when required).
- Safe and uninterrupted operation, no server, no central point of failure
- Warning precisely adjustable, only if really required => strong acceptance by operators/drivers

# KY-OMNI - RECORDED MOVEMENT DATA ANALYSIS

## KY-OMNI PROVIDES UNRECOGNIZED INSIGHTS INTO OPERATIONS

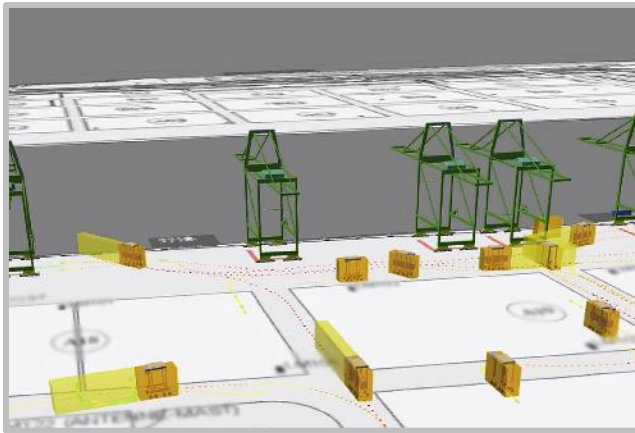

### KY-OMNI Digital Twin

- All CHE displayed, independent of make and age
- replay any scene, any time, from any viewport

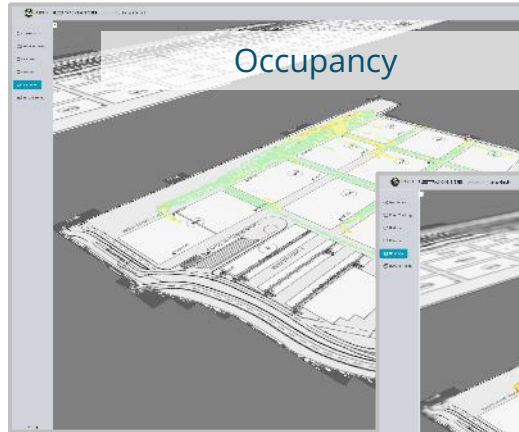

### KY-OMNI data mining Stats visualised:

- Occupancy / time
- Speed / area
- Container sources / destinations
- Your criteria...

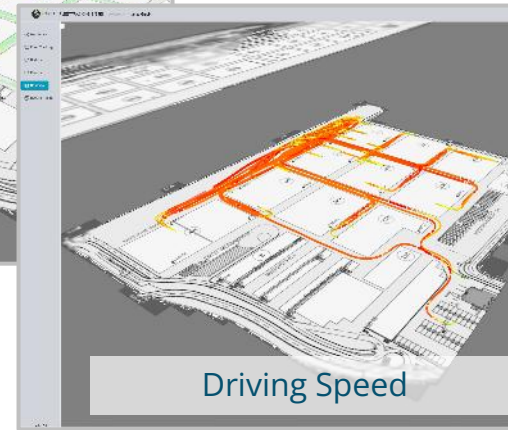

# PRECISE HANDOVER POSITION UNDER CRANES

## GUIDANCE FOR DRIVERS OR AGV OPERATION

### BENEFITS

- Position detection allows precise vehicle position in GPS/GNSS denied areas under and next to the crane.
- Several stopping points for CHE can be preconfigured per each crane, depending on the container size under spreader, crane type and vehicle make (individually).
- Driver gets optical 'car wash-like' position indication (visual and audio) on cabin display
- AGV control receives continuous position in GPS/GNSS format or local coordinates.

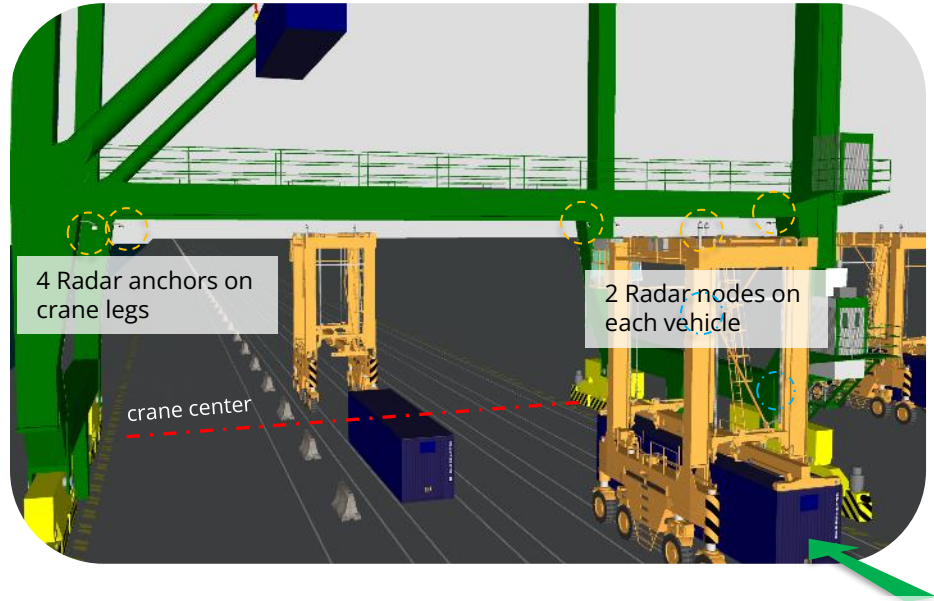

# OTHER CHE INCLUDED IN TRACKING AND COLLISION AVOIDANCE @ MPET

EMPTY HANDLER, TERMINAL TRACTORS + TRAILERS, CARS



WAVES ARE OUR VISION

# KY-LOC 2D - FOR ALL CHE\* TYPES

## APPLICABLE TO FLEETS OF ALL BRANDS

- Kymati 2D Radar & GPS/GNSS position & heading
- ↔ Kymati 1D Radar (distance, speed)
- ⬢ Kymati 3D Radar (speed, presence)
- navigation hub

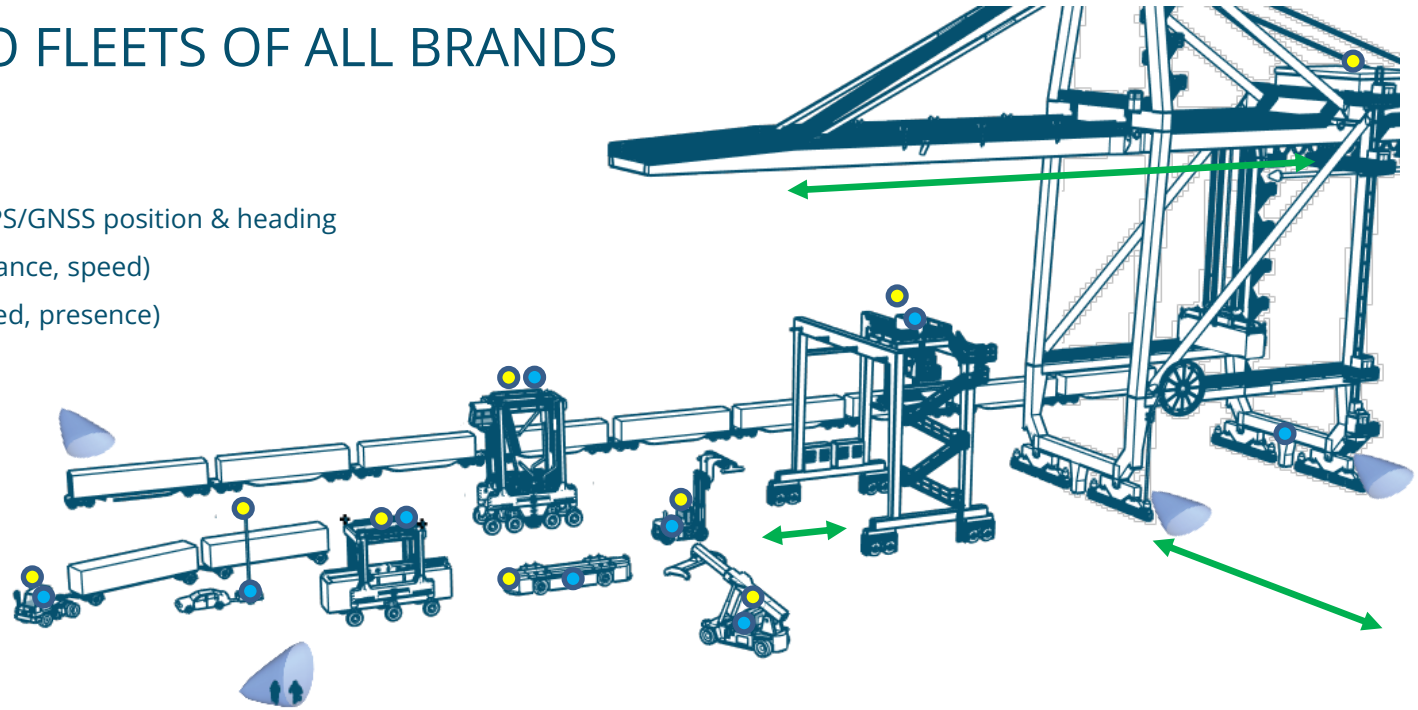

\*) CHE=Container Handling Equipment

WAVES ARE OUR VISION

 **KYMATI**

# KY-LOC 2D: RTG CONTROL & COLLISION AVOIDANCE

## RTGs <> STS SPREADER & CONTAINER <> TERMINAL TRACTORS - ONE SYSTEM FOR ALL

- With only the precise position measured, all static (lightpoles, buildings, stacks) and dynamic objects (all CHE) can be protected in all three dimensions.
- With all vehicles, RTGs and STS cranes, a full digital twin in 3D, dynamically representing all movements and positions of equipment in real time is provided by the optional web-based KY-OMNI application.
- Collision avoidance does not require any server or network connection

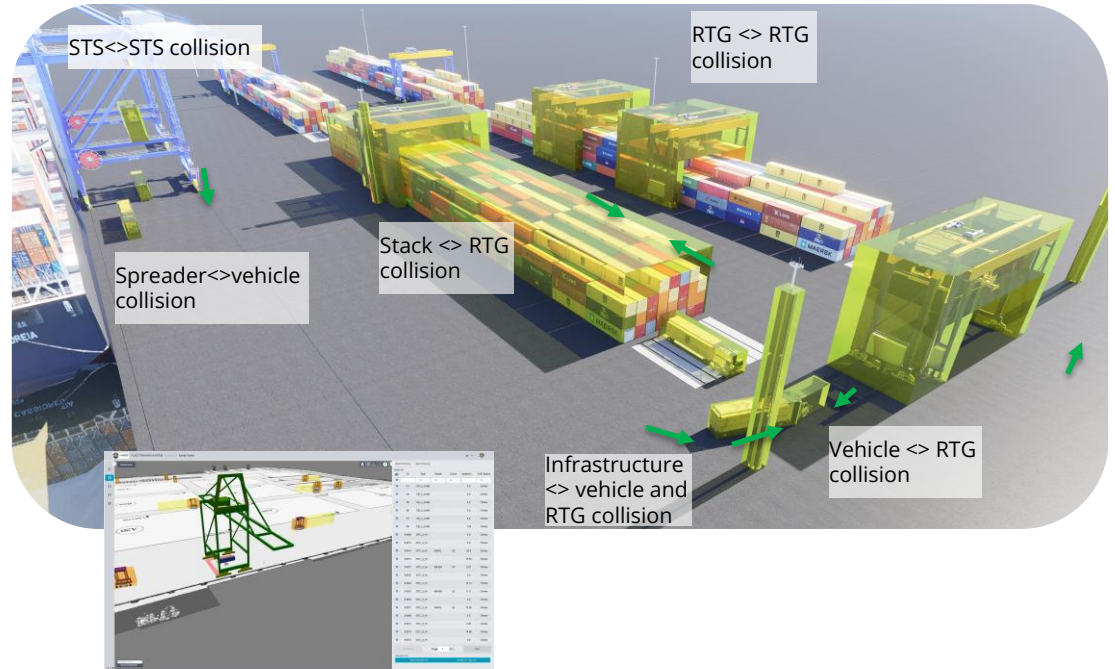

# CONTAINER TERMINALS – STACK PROFILING

## ACTUAL STACK PROFILE MEASUREMENT

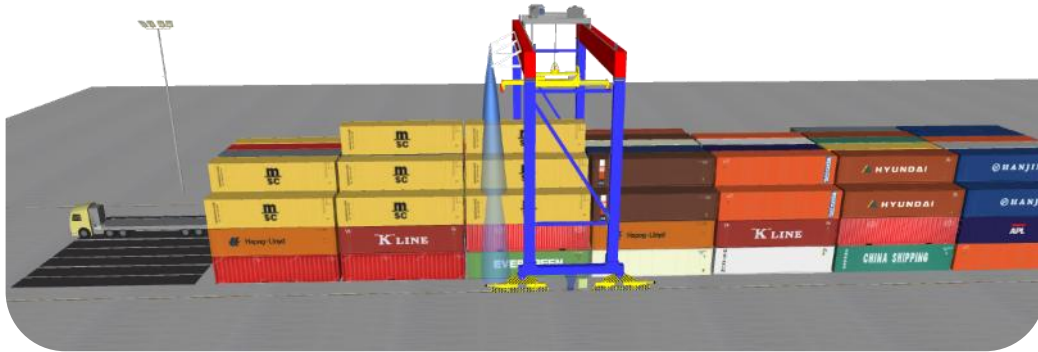

## BENEFITS

- Only 4 sensors for 8 rows required to get complete shape data
- No maintenance, no re-adjustment or cleaning, no interruptions for installation
- High reliability for operational safety and TOS data.



# CONTAINER TERMINAL – ABSENCE & PRESENCE

## OBJECT DETECTION

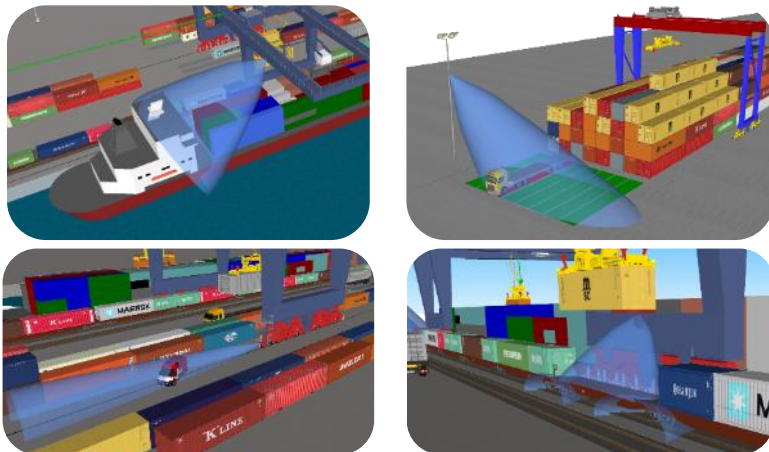

## PERSON DETECTION

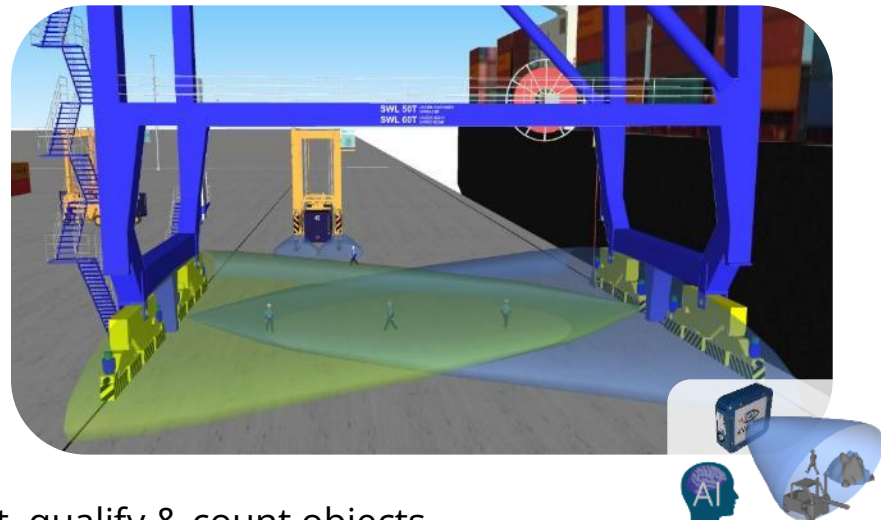

## BENEFITS

- High resolution radar can detect, qualify & count objects
- No maintenance, no re-adjustment or cleaning, no interruptions for installation
- High reliability for operational safety and automation of processes

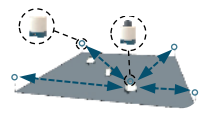

# KY-LOC 2D FOR FULLY AUTOMATED 1OVER1 STRADS

## AUTOMATED 1OVER1 STRADDLE CARRIER POSITION

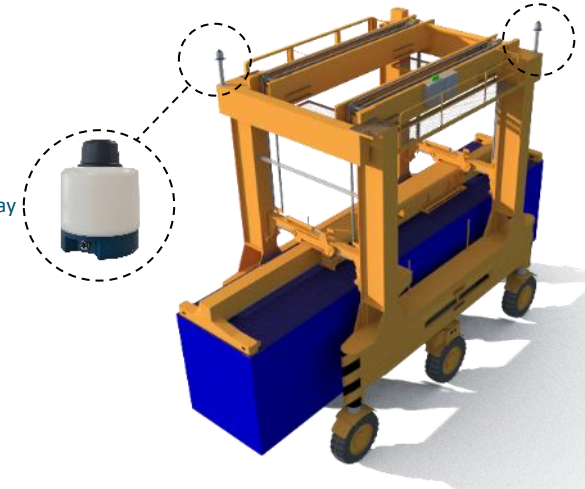
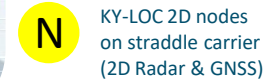
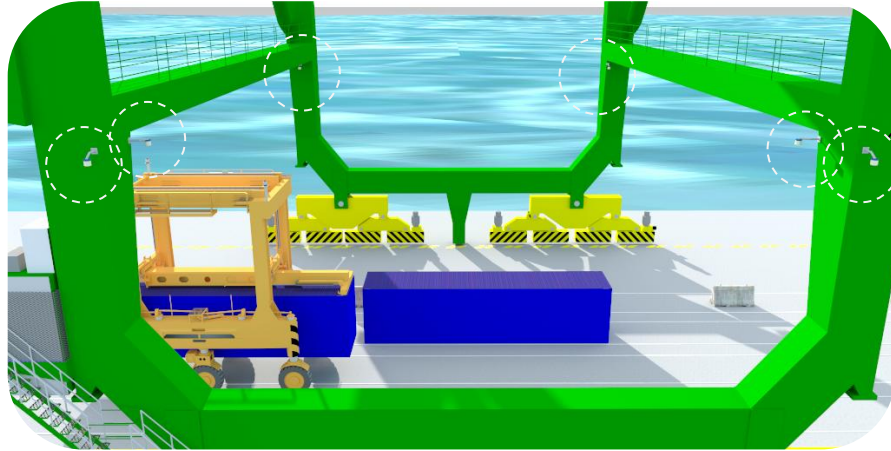

### BENEFITS

- Highly reliable and precise position in GNSS denied areas
- RTK-GNSS used in yard areas – no infrastructure required
- Maintenance-free – no moving parts, not affected by weather or dust
- 2D accuracy  $\pm 3\text{cm}$  with built-in redundancy, for high SIL/PL level of automation

# HORIZONTAL TRAFFIC - FLATBED AGV

## PRECISE 2D POSITION, WITHOUT GPS/GNSS UNDER CRANES AND IN HANDOVER ZONES

- Distance/angle receiver on all four sides of AGV allows precise position and heading measurement to a single reference unit under crane or in the yard
- RTK GPS/GNSS receiver is included in 2D radar nodes. The nodes use Radar and RTK-GNSS simultaneously and fuse position and heading results.

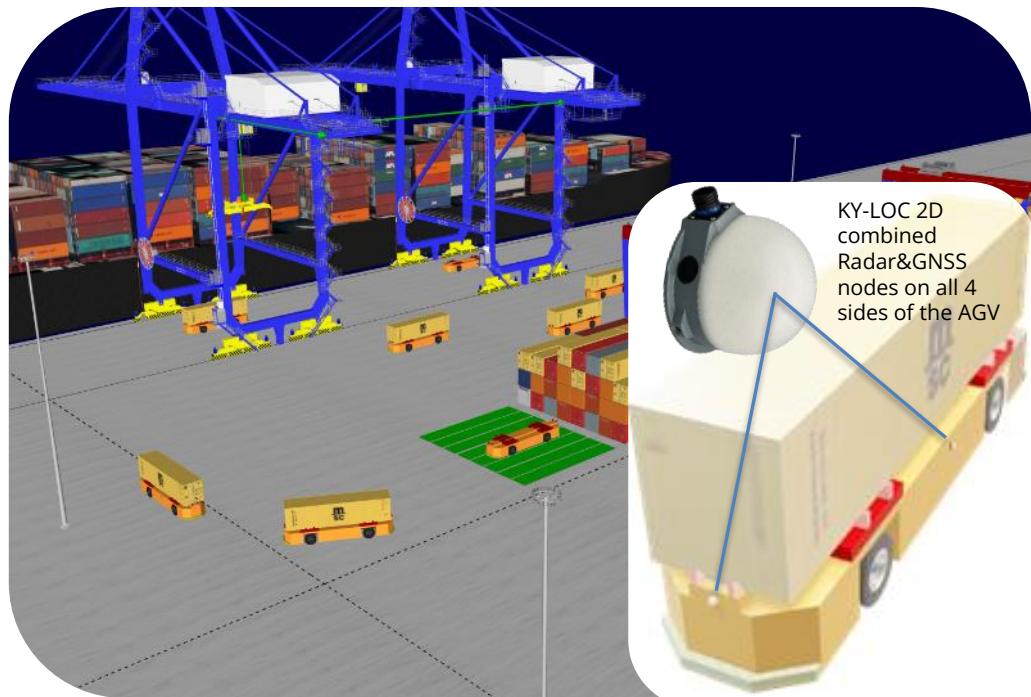

# GET IN TOUCH

---



# KYMATI

WAVES ARE OUR VISION

Kymati GmbH  
Am Hochacker 5  
85630 Grasbrunn  
Germany  
Tel. +49 89 515 75 90 0  
[info@kymati.com](mailto:info@kymati.com)

Meet us. We are around!