



Force Measurement & Systems

Smart Load Management –
Balancing Safety and Efficiency



Facts & Figures

About BROSA

Headquarters

- BROSA GmbH, Tett nang, Germany
- Production and R&D Sensors

Subsidiaries

- BROSAtronic AG, Switzerland
- Production and R&D Electronics, SW

- BROSA B.V., Oss, Netherlands
- Sales Office

- BROSA Pte Ltd, Singapore
- Sales Office

- BROSA (Nanjing) Co., Ltd., China
- Sales Office

Key Figures

- Founded in 1935
- ISO 9001 and ISO 14001 certified

Facts & Figures

About BROSA

- Products are developed in close collaboration with our customers
- Understanding the Trends & Industries
- Compliance with worldwide safety standards
- “Made in Germany”
- More than 90% in house manufacturing
- Full scope of product engineering and manufacturing
 - Specification
 - Technical proposals
 - Production: mechanical, electrical, assembly
 - Calibration
 - Certification, Type Approvals,
 - Customer Acceptance Tests

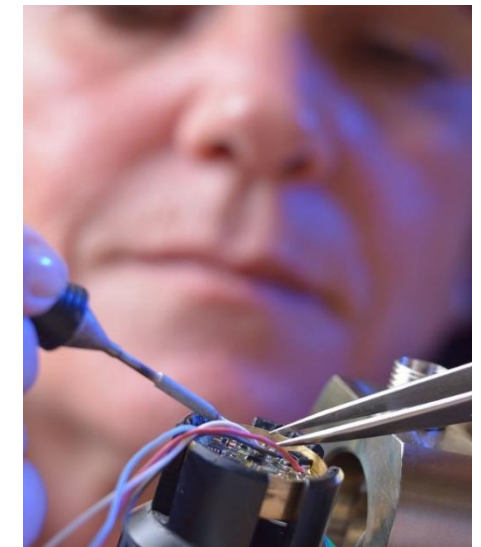
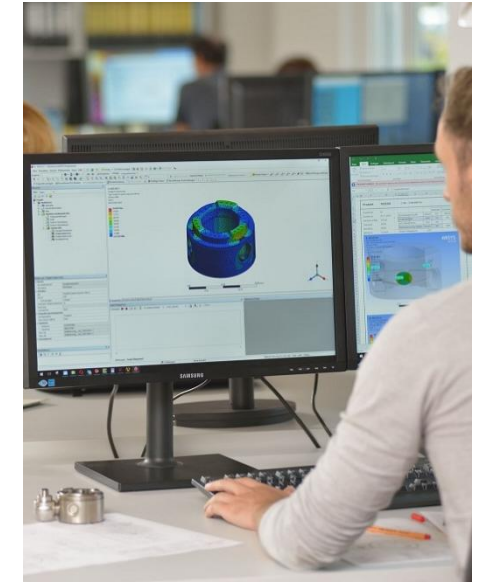

Product

Portfolio



Force measuring pin



Tension load cell



Force sensor washer



Tubular load cell



Compression load cell



Shear force sensor



Rod end load cell



Measuring block



Support jack load cell



Bearing force sensor



Angle sensor MEMS



Pressure transducer



BROSA Electronic



Sensor for Ex area

Safety Sensor Concept

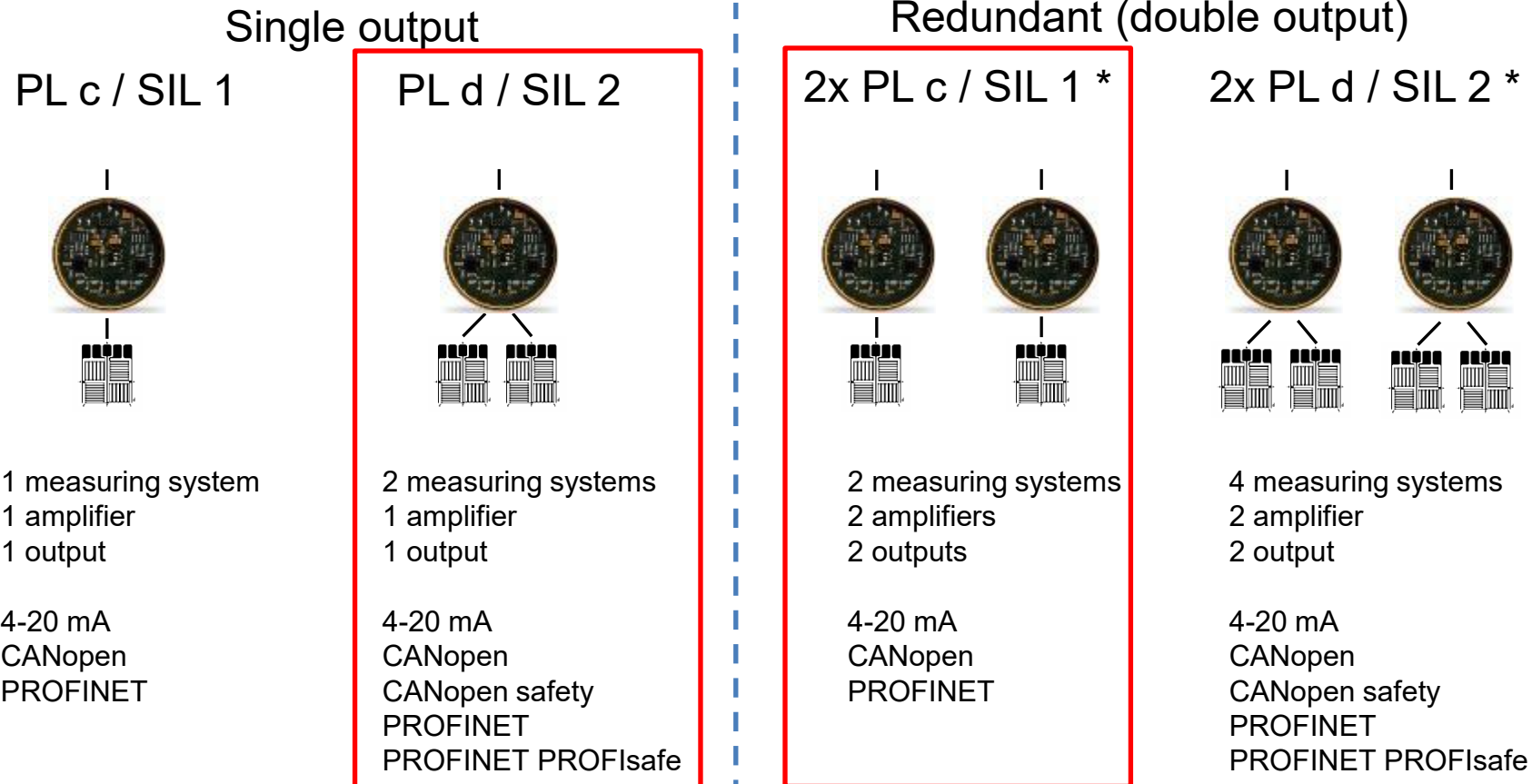

* PL e / SIL 3 is possible if used in parent systems DIN EN ISO 13849-1

Safety System Concept

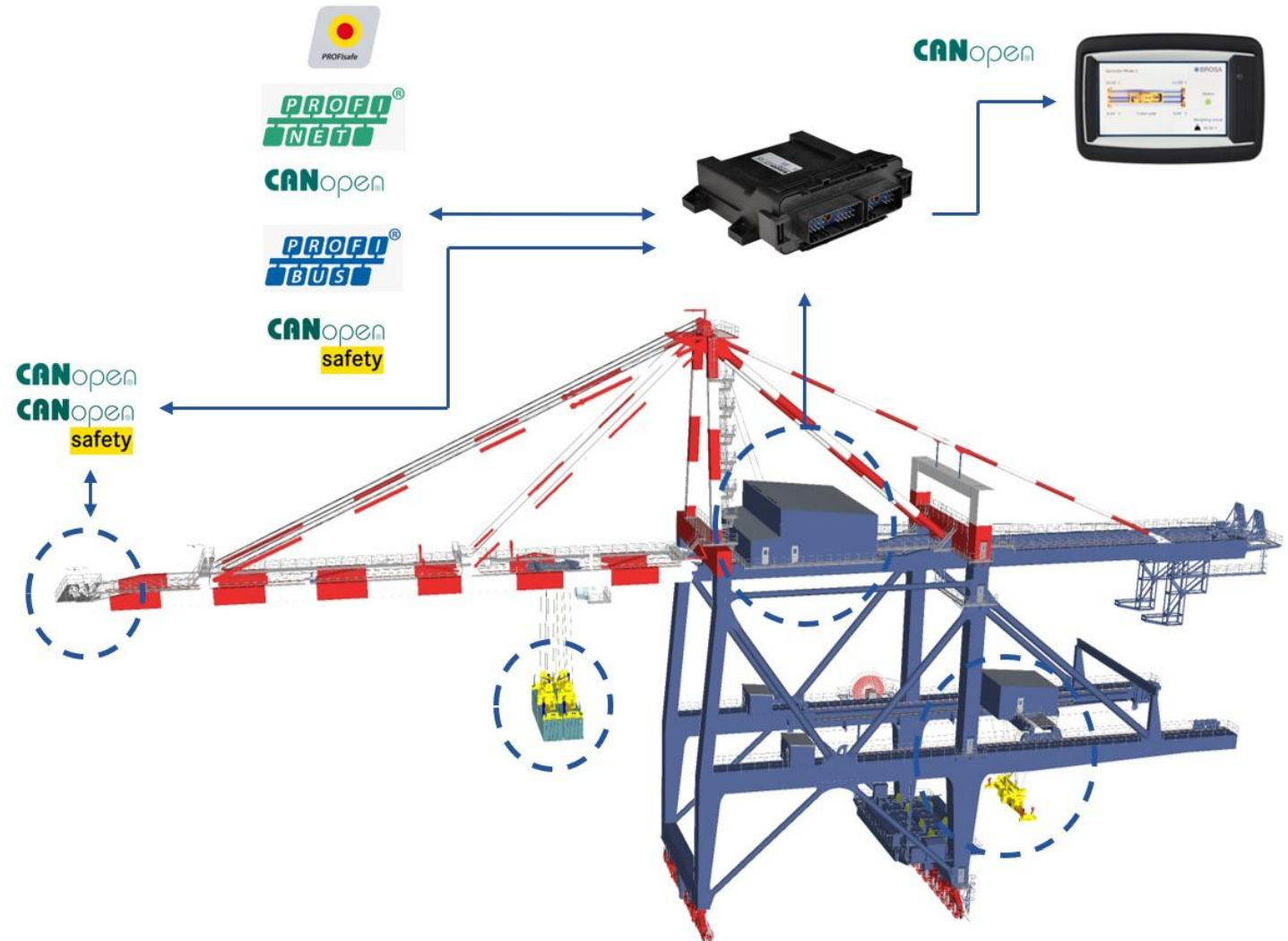

Safety System Concept

Load sensors with CAN in / CAN out



Connection cables 5 pin male / female connectors

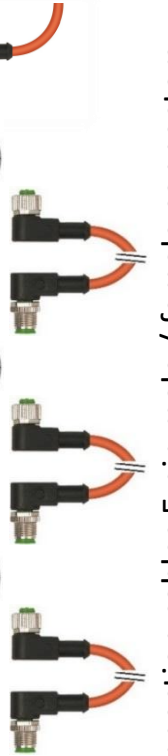



Termination resistor



Electronic System 0656 with connectors and accessories



Profinet



RS232, Profibus



Operator's Display



Crane PLC



Certificates

Weighing & Safety, FMEA, OIML Certificate

Key Data from RP & FMEA

- Standard: IEC 61508 / EN 13849
- Architecture-Category
- Probability of a dangerous failure (PFH)
- Mean Time to a dangerous Failure (MTTFd)
- Diagnostic Coverage of dangerous failures (DC)
- Mission time
- Resulting in Safety Integrity Level
- SIL2 = PLd

Project-No. LUD287D33
Issue: 01
1 Overview:
Block-Nr.
Block-Nam
Architecture
DD
DU
SD
SU
DC
Ice
Ign / Exp
PFH
Requirements
PFH _{int}
SFF _{int}
SIL
Requirements
MTTF _d
DC
PL

Project Nr. LUD013D024	DANGmicro (2 Messbrücken)
Issue: 02	Reliability Prediction & FMEA

The following failure rate Messbrücken)
[Für das Projekt DANGm ermittelt]:

$$\begin{aligned} \lambda_{SD} &= 0,0502 \cdot 10^{-6} \text{ H} \\ \lambda_{SU} &= 0,1230 \cdot 10^{-6} \text{ H} \\ \lambda_{DU} &= 0,1797 \cdot 10^{-6} \text{ H} \\ \lambda_{DU} &= 0,0087 \cdot 10^{-6} \text{ H} \end{aligned}$$

The MTTF_d value of all dan
[Die MTTF_d aller gefährlich

$$MTTF_d = 606 \text{ (10)}$$

* According to the DIN E
years.
[Der MTTF_d ist nach DIN E

The resulting diagnostic co
[Es ergibt sich ein Diagnosti

$$DC = 95,40 \%$$

These values correspond
according to the table K1 in
[Nach Tabelle K1 der DIN
einem Performance Level c

The probability of a dange
[Die Wahrscheinlichkeit ei
be trägt]:

$$PFH = 4,04 \cdot 10^{-9} \text{ H}^{-1}$$

The Safety Integrity Level,
[Der Sicherheits-Integritätsl

$$PL_d = SIL-2$$

Standards and Handbooks
[Normen & Zuverlässigkeits

IEC TR62380
FMD-91
IEC 62061

LUD013D042

Tobias Lu



OIML BASIC
OIML Member State
SWEDEN

Identification of the certi

General description

The load cell type *0120 wit
integrated into twistlock ap
The ring-shaped load cell is
such as measurements in th
positions are possible as we

Technical data

Max capacity, E_{max}
Min capacity, E_{min}
Interval, N_{max}
Minimum load cell
verification interval, V_{min}
EMC class
Temperature range
Power supply
Apportionment factor (p_i)

Interfaces

The load cell may be equip
CANopen (DS404), CANopen



OIML BASIC CERTIFICATE OF CONFORMITY
OIML Member State
SWEDEN
OIML Certificate N°
R60/2000-SE1-17.01



Applicant

Name: Brosa AG
Address: Dr.-Klein-Straße 1, D-8069 Tett nang, Germany

Issuing authority

Name: SP Technical Research Institute of Sweden
Address: Box 857, SE-501 15 Borås, Sweden
Person responsible: Lennart Aronsson

Manufacturer of the certified pattern is the applicant.

Identification of the certified pattern

A graduated, self-indicating, electronic, automatic weighing instrument.

Identification of the certified type

Type: 0120

Accuracy class D(0,23)

Number of verification scale intervals n ≤ 230

(Identification continued on next page.)

This certificate attests the conformity of the above-mentioned pattern (represented by the samples identified in the associated test report) with the requirements of the following Recommendation(s) of the International Organization of Legal Metrology (OIML):

R60, edition 2000.

This certificate relates only to the metrological and technical characteristics of the pattern of the instrument concerned, as covered by the relevant OIML International Recommendation(s).

This certificate does not bestow any form of legal international approval.

The conformity was established by tests described in the associated test report 6P07480-01-1 dated 2017-01-20. This is the first issue of this certificate.

Borås, January 23, 2017

SP Technical Research Institute of Sweden

Certification

Lennart Aronsson

Bengt Gutfelt

OIML Certificate of Conformity no R60/2000-SE1-17.01 dated January 23, 2017, page 1 (2)

SP Technical Research Institute of Sweden

Box 857, SE-501 15 Borås, Sweden

Phone: +46 10-516 50 00

E-mail/Internet: info@sp.se/www.sp.se



OIML Certificate of Conformity no R60/2000-SE1-17.01 dated January 23, 2017, page 2 (2)

SP Technical Research Institute of Sweden

Box 857, SE-501 15 Borås, Sweden

Phone: +46 10-516 50 00

E-mail/Internet: info@sp.se/www.sp.se

SP has been authorized by the Swedish OIML-member to issue and sign OIML-

certificates. Important note: Apart from the mention of the certificate's reference number and the name of the OIML Member State in which the certificate was issued, partial quotation of the certificate or of the associated OIML Basic Type Evaluation report is not permitted, though either may be reproduced in full.

BROSA 3P Sensor Washer

Integration of the Sensor in a Twistlock

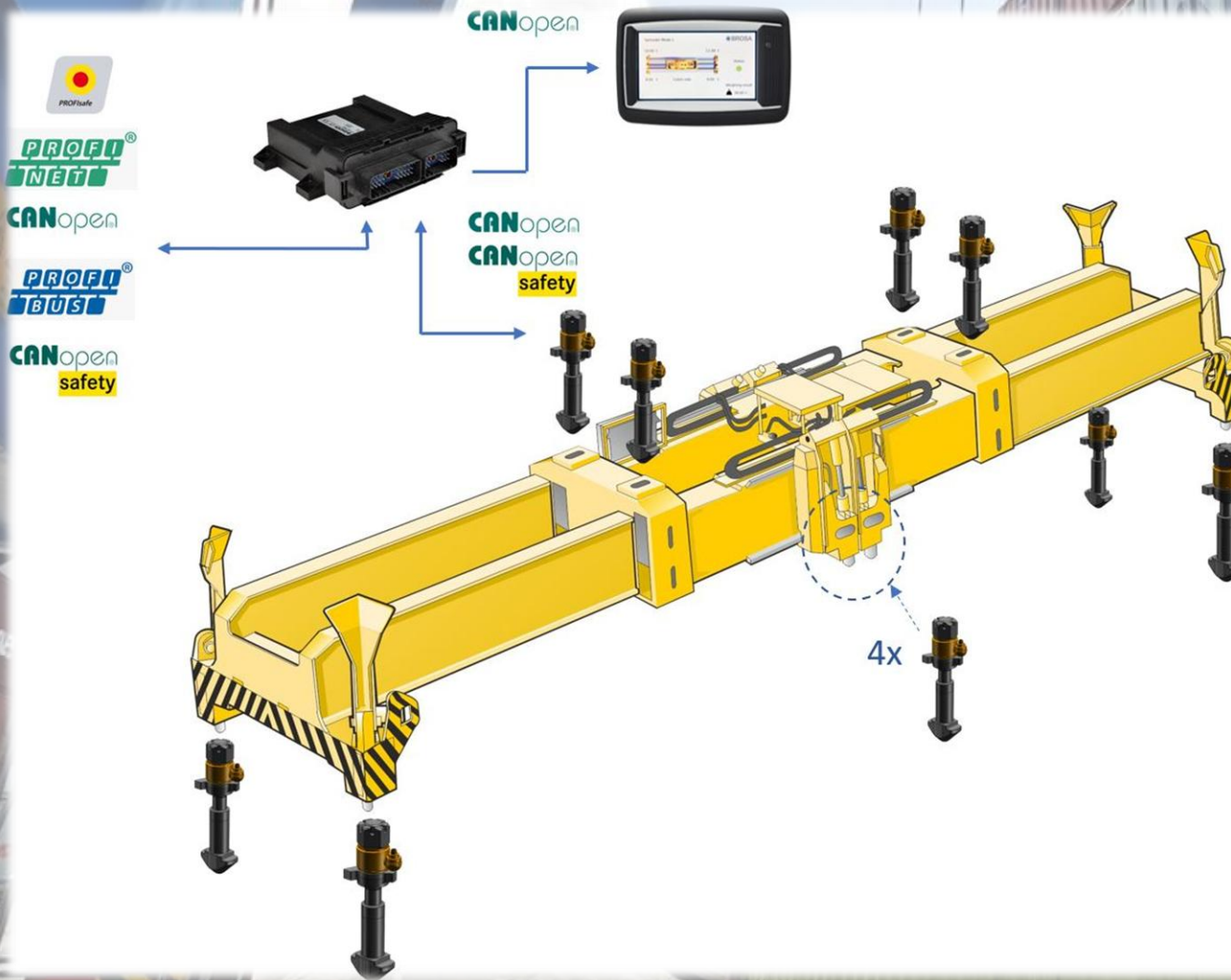
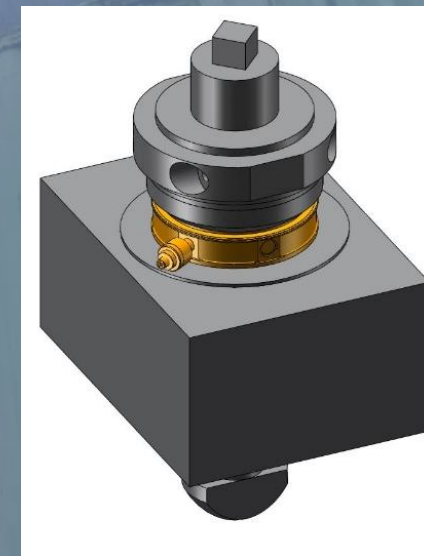

BROSA 3P Sensor Washer

Integration of the Sensor in a Twistlock

- No effect on twistlock cross-section
- Direct force measurement by integrating the sensor into the twistlock assembly
- Tension of the twistlock is transformed into a compression force
- Detachable mechanical assembly
- Can be re-used during twistlock inspection
- Can be re-used after twistlock exchange
- Designed and tested for > 2 Mio. load cycles



Safe Lifting of Loads

Why Safety Systems

- Nearly 25% of accidents in container ports are load dependant. But not in all cases containers are overloaded.
- Safety systems on lifting equipment are a mandatory requirement when loads are lifted
- Monitoring of Safe Working Limits and Operational Limits at all times
- Safety Systems must comply with Safety Standards
- European and International Safety Standards
- Performance Level d (DIN 13849)
- Safety Integrity Level 2, SIL2 (IEC 61508)



Additional & Special Functions

Snag Load Detection

- Dangerous situations occurs when
- A container gets stuck in the railings of a vessel during the lift
- Parts of the spreader block the lift
- When the head covers are not completely removed and obstruct the lifting area
-
- The load sensors are immediately registering a second increase of the load signal
- Once a second increase is detected on any of the load sensors the snag warning can be triggered
- The threshold for the detection is dynamic, dependant on the weight of the container being lifted.

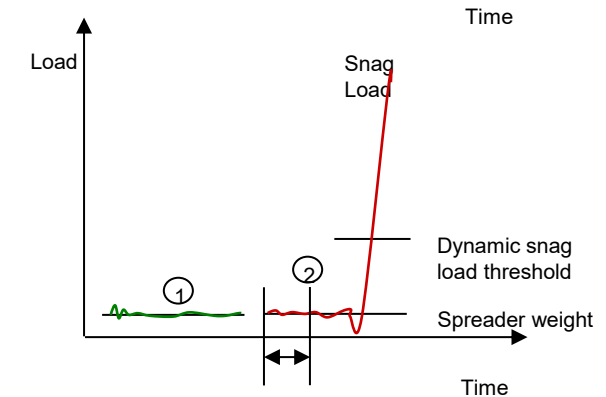
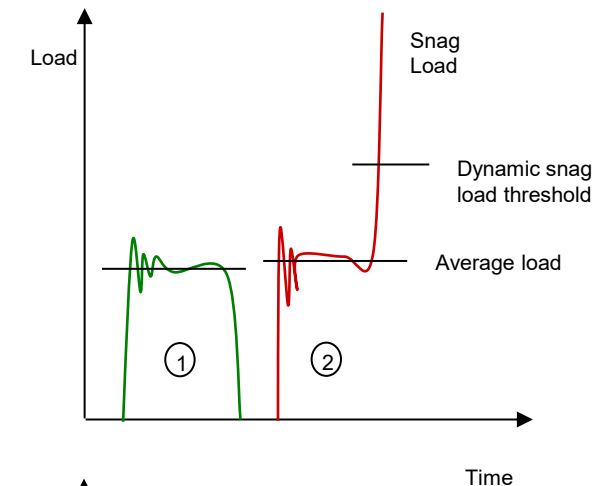

Additional & Special Functions

Lock detection for twistlocks

Dangerous situations occurs when

- One of the twistlocks is not correctly locked in corner
- For Twin-Spreaders: the twin detection system does not detect 2 containers, so that inner twistlocks will not lock



Enhancement for better detection and much more safe lifts

- Installation of force sensor washer on each twistlock
- Load measurement and plausible load checks by start lifting



Mobile Port Equipment

Critical Situations

- Driving at high speed
- Taking turns at high speeds
- Load too high at straddle carrier
- Load measurement at the twistlocks can reduce the possibility of dangerous situations (known weight)
- Knowing the centre of gravity and lifting height can also reduce the possibility of dangerous situations (position)



SOLAS Container Weighing

- Safety issues for extended functions (e.g. SOLAS)
 - Detection of wrongly declared Container Weights
 - Improvement of Ship Stowage Plans
 - All VGM must be taken by a verified system



New Developments

Terminal Automation

- Automation or Industry 4.0 is making his way with big steps into the container handling industry
- Not the individual speed but rather a repeatable speed is the key factor to increase efficiency
- Results shall be sellable time of the operation
- Key Performance Indexes are (next to many others):
 - High equipment availability
 - Minimum downtime (Repairs, Maintenance)
 - Accident prevention
 - Extended equipment lifetime
- Maintenance
 - Corrective maintenance
 - Preventive maintenance
 - Predictive maintenance
- Load sensors and systems to calculate and record lifetime data



New Developments

Lift data vs. Lifetime

Integrated parameters

Sensor

- Service hour meter
- Load collective
- Load cycles
- Overload counter

System

- Time based parameters

Calculation for

- Maintenance intervals
- Machine fatigue & lifetime
- Etc.....

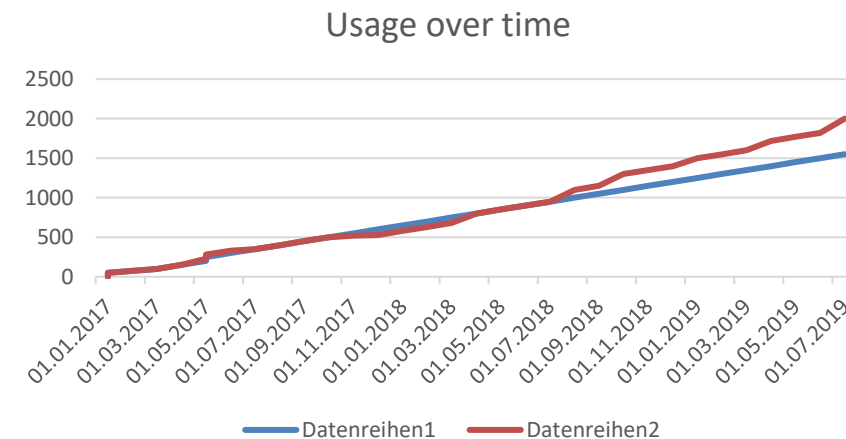
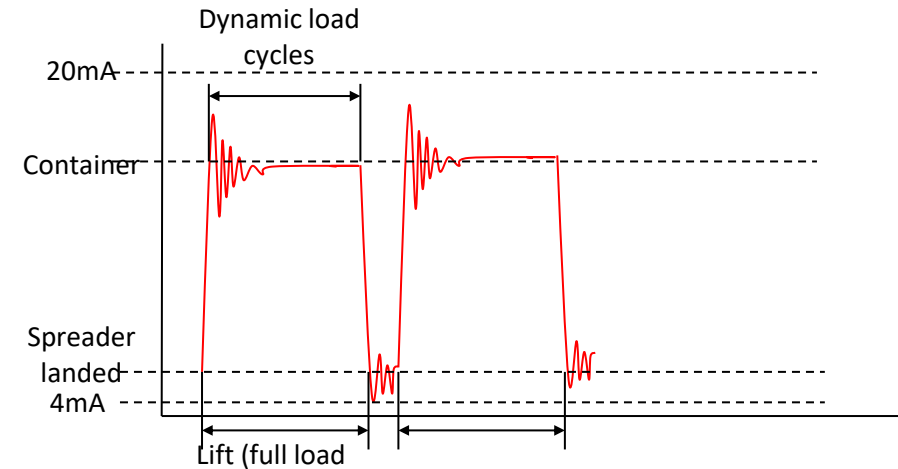

New Developments

Intelligent Sensors

For sensor installation in the headblock

Acceleration = change in velocity

- Change in speed
- Change in direction
- Change in both

Result shall be an increase of the overall accuracy of the load measurement by splitting the load signal in a static and a dynamic signal

During a lift of a container the hoisting speed accelerates while the trolley movement changes the direction.

This causes unwanted effects into the measurement of the force created by the container

The amplifier inside the sensor needs to calculate the dynamic forces

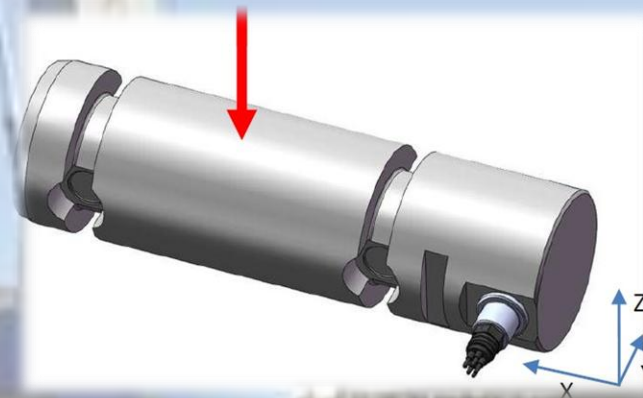

Users & Customers

Overview



BROSA GmbH

Sensor and System

- A competent partner for load sensing and monitoring
- A leading supplier to the container handling industry
- An innovation driven development partner for future oriented products
- Supplier to all major crane and port equipment manufactures
- Products are used in all major ports around the world.





BROSA GmbH

Contacts

BROSA GmbH

Dr.-Klein-Straße 1

D-88069 Tettnang

Phone +49 (0)7542-9335-37

Fax +49 (0)7542-9335-35

Michael.Paschko@brosa.net

www.brosa.net



BROSA

Force Measurement & Systems